

REV.	DESCRIPTION	ECN NO.	NAME	DATE
0	FIRST EDITION	N/A	Liu	2021-04-12

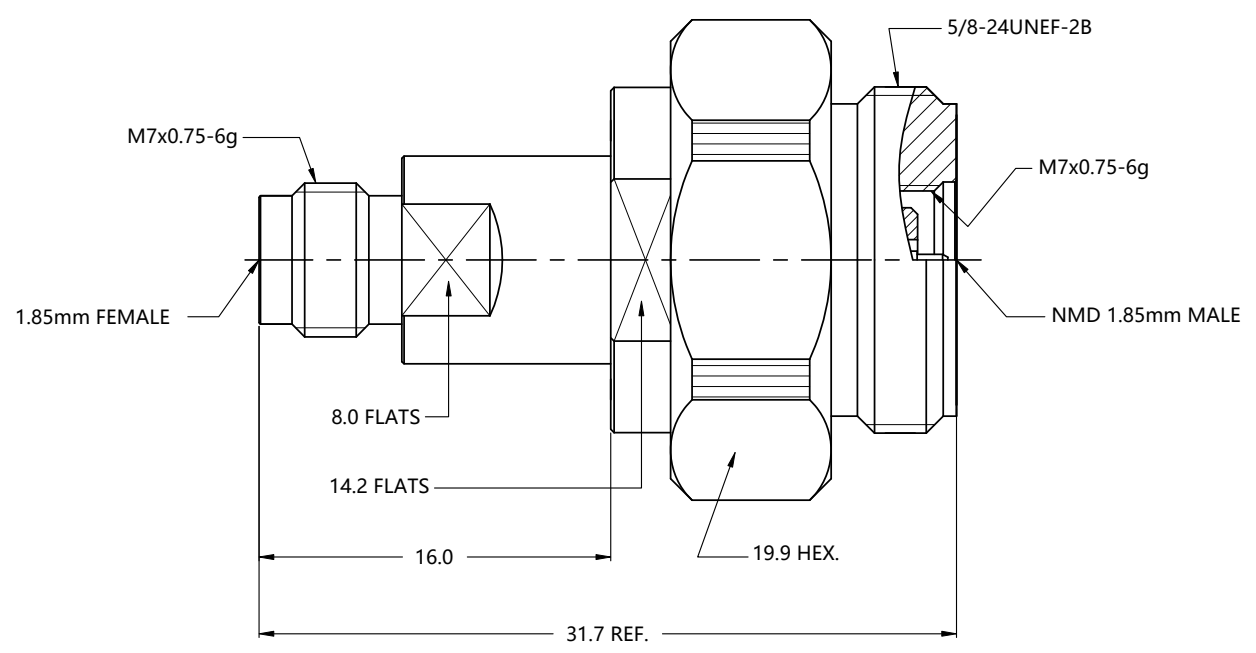

ALL PARTS MUST MEET TO RoHS REQUIREMENTS



MATERIALS AND PLATING		UNIT: MICRO-INCHES
PART NAME	MATERIALS	PLATING
BODY/SHELL	STAINLESS STEEL 316F	PASSIVATION
INSULATOR	PEI	N/A
CONTACT PIN	BERYLLIUM COPPER C17300	PL.GOLD/COPPER

ELECTRICAL CHARACTERISTICS	
IMPEDANCE	50 Ω
VOLTAGE RATING	175 V(rms)
FREQUENCY RANGE	DC ~ 67 GHz
DIELECTRIC WITHSTANDING VOLTAGE	> 500 V
CONTACT RESISTANCE	CENTER CONTACT < 2.2 mΩ
	OUTER CONTACT < 0.15 mΩ
INSULATION RESISTANCE	> 5000 MΩ
INSERTION LOSS	< 0.05√F(GHz) dB
RETURN LOSS	< 1.25

MECHANICAL CHARACTERISTICS	
FORCE TO ENGAGE AND DISENGAGE	N/A
CENTER CONTACT RETENTION FORCE	> 6 lbs
RECOMMENDED COUPLING TORQUE	9~ 14 in-lbs
COUPLING NUT RETENTION FORCE	> 100 lbs
DURABILITY	> 500cycles

ENVIRONMENTAL PARAMETER	
TEMPERATURE RANGE	-40 °C~+85 °C
CORROSION	US MIL- STD 202, Meth. 101,Cond. B
VIBRATION	US MIL- STD 202, Meth. 204,Cond. D
SHOCK	US MIL- STD 202, Meth. 213,Cond. I
THERMAL SHOCK	US MIL- STD 202, Meth. 107,Cond. B

**\* CUSTOMER OUTLINE DRAWING**

UNLESS OTHERWISE SPECIFIED:  
 1) EDGES : C0.15 MAX ;  
 2) REMOVE ALL BURRS ;  
 3) SURFACE ROUGHNESS : Ra1.6 ;  
 4) UNITS : mm ;  
 5) DIMENSIONS TOLERANCES  
 DECIMALS : .x ±0.3 .xx ±0.2 .xxx±0.1;  
 ANGLES : ± 5°.

THIRD ANGLE PROJECTION	
APPROVED :	CUSTOMER P/N :
CHECKED :	SCALE : 3:1
DRAWING :	DATE : 2021-04-12
PAGE : 1/1	

TITLE : 1.85mm FEMALE TO 1.85mm MALE S/T NMD ADAPTOR ,50 Ω  
 DRAWING NO. : T-5P1F06S-P1M-005  
 COMPANY WEBSITE : www.slkcorp.com

CUSTOMER OUTLINE DRAWING